

Segura 2

Coughtrie

Custodial

NOMS 3 approved patented anti-ligature design (Patent No. 11797486-2423). Praised for its innovation, the Segura anti-ligature custodial range has been designed and constructed for ease of installation and maintenance. With cable channels running behind the fitting, the design ensures that all cabling is completely enclosed.

Applications

- Secure cells
- Secure hospital accommodation



Features

- 2mm reinforced Zintec Body, pretreated and powder coated
- Three 21x30mm cable channels running behind the fitting suit cable entry at either end
- Twin UV stabilised polycarbonate diffusers totaling 12.5mm thick ensure maximum strength
- Silicon gasket used throughout to seal all panels and o-ring washers on each external screw
- Pin Torx security screws, as specified by the Ministry of Justice used for all fixings
- IP65
- IK10++

Options

- RAL 9010 as standard
- Screws as specified Pin Torx, other to order
- Self-test Module POA
- 3-hour Non-Maintained emergency versions POA
- Dusk to Dawn POA

CE BS.EN60598-2-1 IP65

Segura 2

Coughtrie

Dimensions (mm)

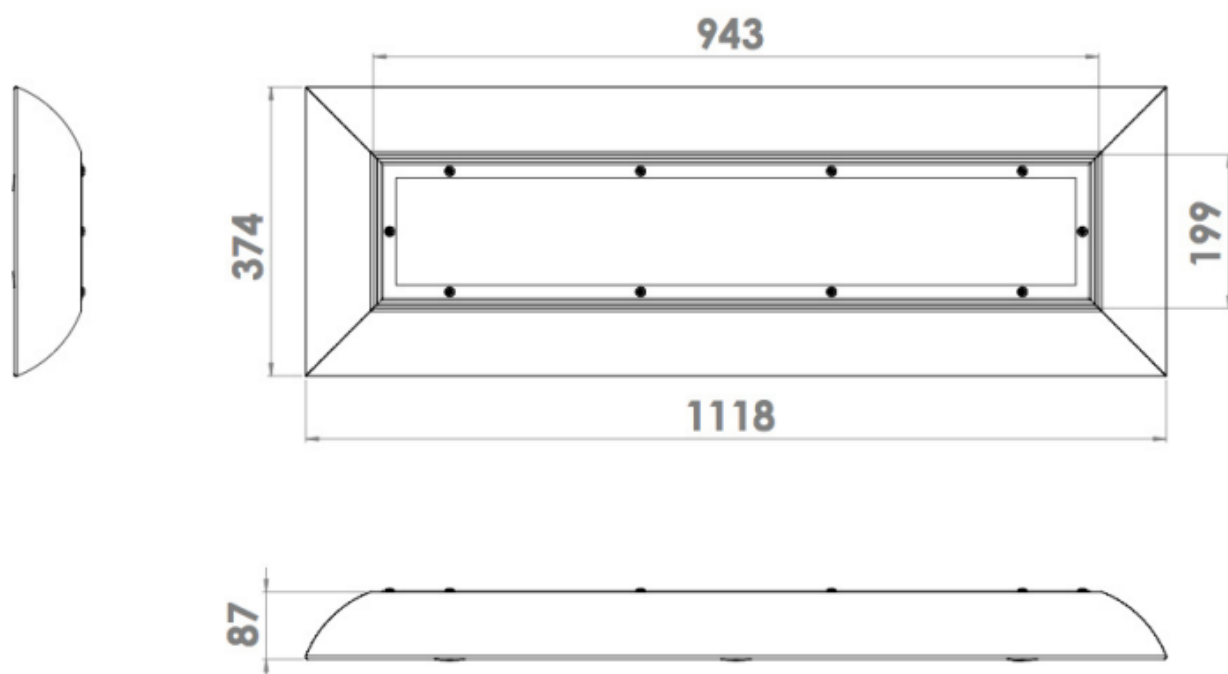

Lamp Types

30W LED	SGC-30LED
40W LED	SGC-40LED

Other LED options available on request

Sample Order Code

SGC-40LED	+	EMG	+	DD	/	RAL 9010	/	OP
Luminaire		Emergency		Sensor		Finish		Diffuser
SGC		Emergency = EMG		Dusk to Dawn = DD Corridor Function = CF CF+Daylight Monitoring = CFDM Microwave = MWD		RAL 9010		Opal = OP

SGC-40LED+EMG+DD/RAL9010/OP = 40LED, Emergency, Dusk to Dawn, RAL 9010, Opal Diffuser

CE BS.EN60598-2-1 IP65