

SP 24W LED

Coughtrie

Heritage

Interior

Rail

The most versatile fitting from our heritage portfolio. The SP is a classic, wall or ceiling mounted luminaire used for industrial and now retro/architectural applications. The fitting is section 12 approved for rail tunnel applications and is 1000hr salt spray test approved for marine applications.

Applications

- Retro internal applications including pubs
- Marine
- Railway tunnels
- Outside coastal cottages
- Industrial and commercial properties



Features

- Die-cast aluminium base and flange, pre-treated and polyester powder coated
- 20mm threaded AB entry and low smoke moulded nitrile sealing ring
- Clear or Pearl Glass
- IP65

Options

- Antique Bronze, Black, Grey or White
- Any RAL colour POA
- Integrated 3hr emergency & optional self-test
- Motion sensors - on/off or on/dim (10%), daylight monitoring
- Dusk to Dawn
- Microwave
- Corridor Function + Daylight monitoring

CE BS.EN60598-2-1 IP65

Technical Specifications

LUMINAIRE CHARACTERISTICS	
LEDs	Tridonic LLE ADV
DRIVER	Constant current
WORKING TEMP	-25°C to 50°C
EMERGENCY WORKING TEMP	-5°C to 50°C
SYSTEM LUMENS	2400lm
EFFICACY	119.4lm/W
CRI	>80
CCT	4000K
LIFETIME	50,000hrs
IP RATING	IP65
ELECTRICAL CHARACTERISTICS	
POWER	20.1W
VOLTAGE	40V
CURRENT	500mA

Dimensions (mm)

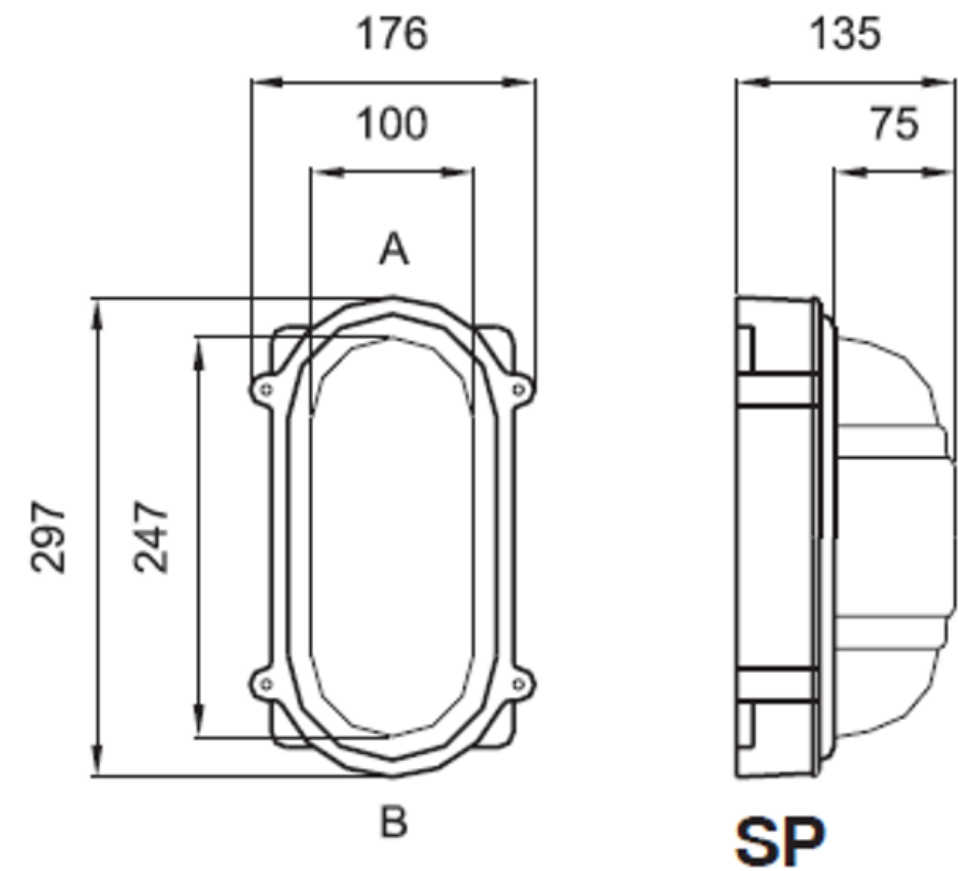

Photometric Data

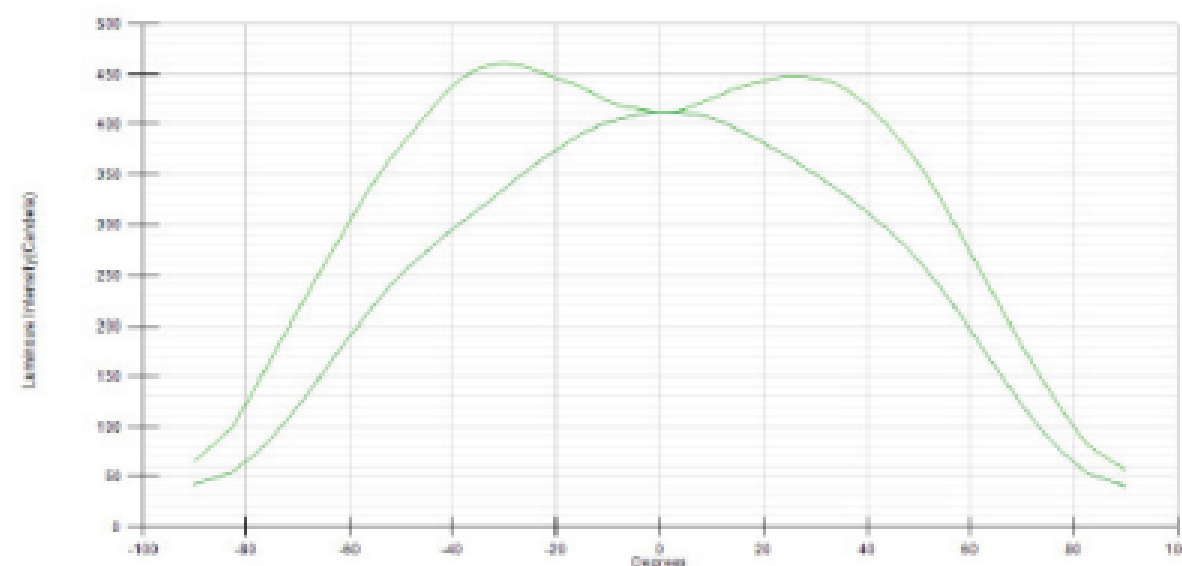
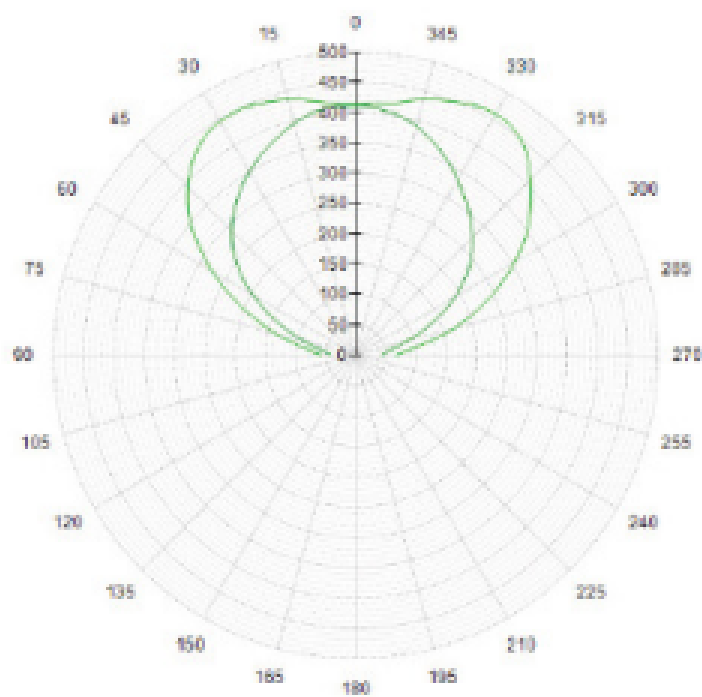

Sample Order Code

SP-24LED	+	EMG	+	MWD	/	BRONZE	/	CL
Luminaire		Emergency		Sensor		Finish		Diffuser
SP		Emergency = EMG		Dusk to Dawn = DD Corridor Function = CF CF+Daylight Monitoring = CFDM Microwave = MWD		Antique Bronze = BRONZE Black = B Grey = G White = W		Clear = CL Pearl = P

SP-24LED+EMG+MWD/BRONZE/CL = 24WLED, Emergency, Microwave, Antique Bronze, Clear Glass Diffuser